



# LogiLink®

## VESA Mount Clamp

For Smartphones and Tablets

Art. No.: BP0204  
BP0204W



## Working Ergonomically!

Seamlessly integrate the tablet or smartphone onto a multi-display setup, improving productivity and workflow, while saving space.

Art-No.	Color	EAN Code
BP0204	Black	4052792073379
BP0204W	White	4052792073386



\*The specifications and pictures are subject to change without prior notice.  
\*All trade names referenced are the registered trademarks of their respective owners.



### Universal Mount

Retractable clamp firmly holds most 4.7–15" phones and tablets in place.

### Sleek Design

Blends into various modern interior designs.



### VESA Compatible

Fits 75x75 VESA monitor mount\*, quick and easy installation.

\*Check out the available LogiLink monitor mounts:

<https://www.2direct.de/buero-haushalt/monitorhalterungen/>



### Viewing Comfortably

Mounting a tablet on a monitor arm can make data entry much easier in retail, hospitality and food service environments.

## Specifications:

Applicable Device	4.7–15" smartphone/tablet
Weight Capacity	Up to 1 kg
VESA Compatible	75 x 75
Adjustable Holder Width	11.5–26.5 cm
Installation	Bolt-down base
Materials	Silica gel, steel, plastic
Dimensions	8.5 x 3.8 x 13–28 cm
Color	Black

## Package Contents:

- » 1 x VESA Mount Clamp
- » 1 x Screw Package
- » 1 x User Manual

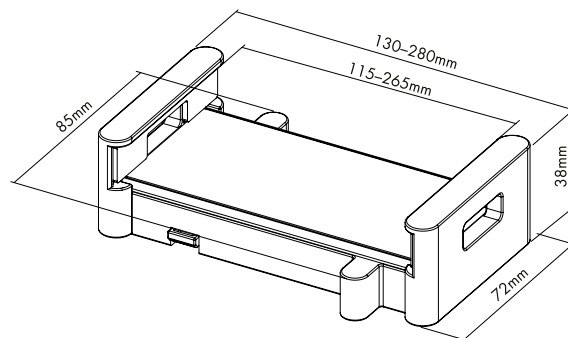

## Package Information:

Art-No.	Packing Dimension	Packing Weight	Carton Dimension	Carton Q'ty	Carton Weight
BP0204	90 x 45 x 140 mm	0.2 kg	470 x 290 x 300 mm	60 pcs	13.2 kg
BP0204W	90 x 45 x 140 mm	0.2 kg	470 x 290 x 300 mm	60 pcs	13.2 kg